

MEMORANDUM

STATE OF ALASKA

Department of Transportation & Public Facilities
Office of the Commissioner



TO: Regional Directors, Maintenance Team Leaders
DATE: June 29, 2026
FROM: Ryan Anderson, P.E., Commissioner 
SUBJECT: FY2027 Guardrail Repair Funding Allocation and Prioritization

The purpose of this memorandum is to allocate state funding for guardrail repairs that are not eligible for federal participation, establish department-wide repair priorities, and provide direction for supplemental funding beyond routine regional maintenance budgets.

The FY2027 guardrail repair allocation includes a \$1.7 million capital appropriation, \$1.68 million in reallocated funding available for immediate deployment, and \$1.0 million designated for the Dalton Highway. Regional allocations are based on each region's share of guardrail inventoried in poor condition, ensuring funds are directed where system needs are greatest.

Funding shall be prioritized consistent with the Department's Guardrail Field Inspection Rating Guide, with first priority given to Grade F ("Priority – Replace") deficiencies, including damaged or non-functional end terminals, anchor systems, missing or broken posts, and other safety-critical components requiring replacement.

Region	Percent	FY27 Approp.	Reallocated Funds	Total
Central Region	39%	\$663,000	\$655,200	\$1,318,200
Northern Region	35%	\$595,000	\$588,000	\$1,183,000
Southcoast Region	26%	\$442,000	\$436,800	\$878,800
Dalton Highway (Northern)	N/A	N/A	\$1,000,000	\$1,000,000
Total	100%	\$1,700,000	\$2,680,000	\$4,380,000

Regional Directors shall ensure that available funding is used to address the highest-priority safety deficiencies and that repairs are completed as expeditiously as practicable.

Attachment: *Field Inspection Rating Guide for Existing Guardrail (2020)*

FIELD INSPECTION RATING GUIDE FOR EXISTING GUARDRAIL



2020

EXISTING GUARDRAIL FIELD INSPECTION GRADING

CONTENTS

RATING GRADES/PRIORITY..... 4

GRADE F - REPLACE

GUARDRAIL

F-MISS –		
GUARDRAIL	Missing guardrail	7
F-MISS-POST	Missing/broken posts	7
F-DEFL	Post & guardrail deflection > 9”	8
F-HGT	Existing guardrail height	8
F-IMPR-SPLC	Improper splice	9
F-SPLICE-		
BOLTS	Damage at guardrail splice	9
F-EMBD	Loss of post embedment	10
F-VERT-TEAR	Vertical tear	10
F-HOLES	Non-manufactured hole size	11

TERMINALS

FT--HIT-TERM	Activated/kinked terminal	12
FT-HGHT	Terminal height too low/too high	13
FT-SLPD-END	Sloped concrete end at 35 MPH+	13
FT-REFL	Web reflectors in terminal	14
FT-TX-TWST	Texas Twist	14
FT-MOD	Modified terminals	14
FT-NO-TRANS	No stiffened transition	15
FT-NO-BRIDG	No bridge connection	15
FT-DEND-		
POST	Damaged end post	16
FT-BCT	BCT Terminals	16
FT-MISS-CBL	Missing anchor cable	17
FT-MFR-		
INSTR	Steel yielding , posts on wrong side	17
FT-TERM-		
OFFST	End terminal offset too far	18
FT-NO-BRGPL	Missing bearing plate	18
FT-MFR-INSTR	Incorrect terminal installation	18
FT-LAG	Lag screws	19

EXISTING GUARDRAIL FIELD INSPECTION GRADING

CONTENTS

GRADE D - REPAIR

GUARDRAIL

D-POST-SEP	Posts separated	20
D-MIS-BLKT	Missing blockouts	20
D-TWST-BLKT	Twisted blockouts	21
D-DEFL	Post & rail deflection ≤ 9”	21
D-HORIZ-TEAR	Horizontal tear	22
D-FLAT-RAIL	Guardrail flattening	22
D-SPLIC-BOLT	Damage at guardrail splice	23
D-SHORT-		
TRANS	W-Beam (29”) to W31	23
D-REFL	Web reflectors location poor	24

TERMINALS

DT-STRUT	Stub height or “floating strut”	24
DT-FLARE	Parallel Terminal Widening	25
DT-CBL-SLK	Anchor cable	25
DT-CBL-		
ANCHR	Cable anchor bracket	25
DT-ANCHR-		
SPLIC	W31 End anchor splice incorrect	26
DT-BRG-PLT	bearing plate	26
DT-BRDGEGAP	Poor bridge connection	27

GRADE A-B-C

LONG SPAN GUARDRAIL.....	27
TERMINAL IDENTIFICATION.....	29
LENGTH OF NEED.....	35

GUARDRAIL FIELD
INSPECTION
RATING GUIDE

(F) PRIORITY
Replace

GRADE F
Unacceptable

Existing guardrail condition is poor, significantly damaged, or deteriorated towards its end of life.

Guardrail considered unable to absorb another vehicular impact and is a safety concern. A second impact results in unacceptable safety performance including barrier penetration and/or vehicle roll over.

Document unacceptable elements as a priority for consideration of replacement by all projects.



(D) DAMAGED
Repair

GRADE D
Damaged but functional

Existing guardrail condition is fair overall. Meets height standards. Isolated locations of damage, but no moderate or severe damage.

Guardrail considered functional - able to absorb additional vehicle impacts with acceptable safety performance.

Document damaged elements for repair, maintenance, or replacement under rehabilitation projects.



(A) ACCEPTABLE
Remain in place

GRADE A-B-C
New or Acceptable

Existing guardrail shows little or no damage.

Condition is excellent to fair with minimal damage. Posts and rail appear to be in good working condition.

Documented inventory or field inspection ratings are not required. No repairs identified.



GRADE F RAIL: Priority conditions- Replace

F-MISS-RAIL

Missing Guardrail

- Replace as soon as crews are available
- Consider temporary barrier, crash cushions for extended periods (> 10 days during Construction)



F- MISS-POST

Missing / Broken Posts

- 1 or more posts missing, cracked across the grain, broken, rotted or with metal tears, disconnected from ground level.
- Includes end posts on guardrail terminals

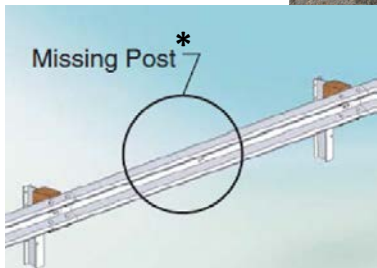

*Exception:
Std Plan G-29
with 3 CRT
posts each side

F-DEFL

Post & Guardrail deflection > 9"

Over a 25' length of guardrail (between any 4 standard posts):

More than 9" of lateral deflection

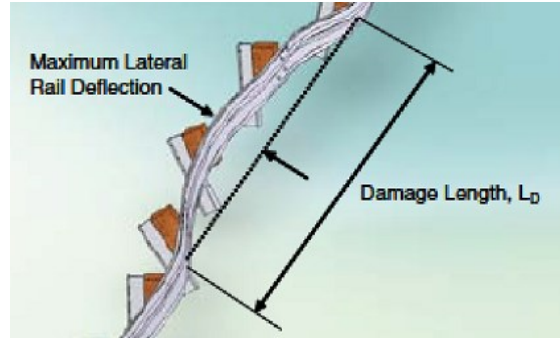

F-HGT Existing Guardrail Height (in-service):

Too low or Too high

Over a 25' length of guardrail (between any 4 standard posts) top pavement to top rail:



Top of W-Beam guardrail less than 26 - 1/2" when spliced at post only (2017 and earlier installations.)

* Top of W-Beam or W31 rail higher than 32"

* 28" required after raising pavement 29" (+3", -1")
(2011 AASHTO RDG
pg. 5-17, Std Plan G-04)

* Top of W31 guardrail less than 30" when spliced between posts. (2018 and later installations)

(Std Plan G-05)

*Height required when changing pavement elevation

F-IMPR-SPLC

Improper Splice

- Splice not consistently located at posts for older 29" guardrail. ($\leq 29"$ Height)
- Allowed at 3' midspan only for 31" guardrail per Std Plan G-05 as of 2018 forward, Not < 3' off adjacent post



F-SPLICE-BOLTS

Damage at guardrail splice (2 or more splice bolts damaged)

2 or more splice bolts:

- Missing
- Damaged
- Visibly missing any underlying guardrail
- Torn through guardrail

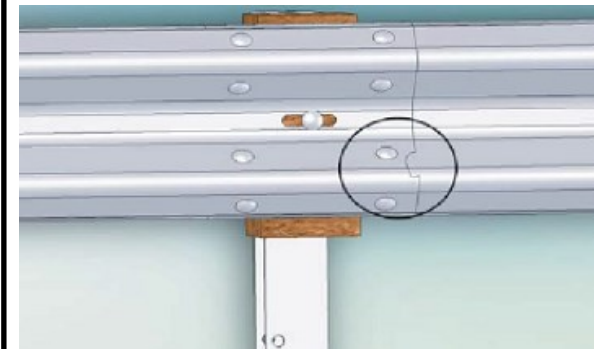

F-EMBD

Loss of post
embedment

More than one post too
exposed due to erosion
(6'-7' of post exposed)
See Std Plan G-10



F-HOLES

Non-manufactured
hole size, spacing

- Crash-induced holes, lug nut damage, or holes rusted through the guardrail, including:
- Any holes with a height greater than 1"
- More than 2 holes with a height less than 1" over a 12.5' length of rail
- Any hole which intersects the top or bottom edge of guardrail

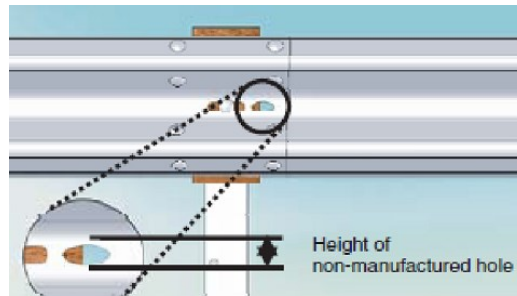

F-VERT-TEAR

Vertical Tear

Any length vertical
(transverse) tear

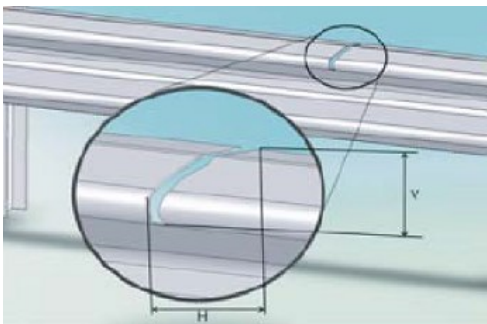

GRADE F TERMINALS: Priority conditions - Replace

FT-HIT-TERM

“Activated” or Kinked Energy
Absorbing Terminal
or Crash Cushion

Impacted terminal no longer functional.

Repair or replace during routine maintenance and
during work zone activity.

More than one post sheared or cracked.

Damage to foundations that disallows repair.



FT-HGHT

Over length of terminal (37.5' to 50')

Terminal Height too low or too high:

Top of NCHRP 350 or BCT terminal is less than 26 - 1/2" or > 30"

Top of MASH terminal is < 30" or higher than 32"



FT-REFL

No web reflectors within 50' end terminal.
Post top reflectors OK



FT-NO-TRANS

No stiffened transition

Guardrail transition not stiffened with increasing post density prior to rigid guardrail barrier/wall/ bridge connection



FT-TX-TWST

"Texas Twist"

"Texas twist" is a turned down guardrail end bolted to ground level



FT-NO-BRIDG

No bridge connection

Guardrail transition not attached to bridge guardrail with a transition piece – there may be a gap between w-beam rail and bridge rail, with no connection.

May be older bridges – preexisting designs at the time. New standards may require opposing direction treatment.



FT-SLPD-END

Sloped concrete ends at 35 MPH+

Do not use for speeds of 35 MPH or higher within the clear zone

Only for temporary or low speed use of 30 MPH or less. (2011 AASHTO RDG 9.2.2)



FT-MOD

Modified Terminals

No timber drainage barrier curb or open rock down drains within end terminal area 50'

No web reflectors on 50' terminals.

Use end delineators only.



FT-DEND-POST

Damaged End Post

Not functional (sheared, rotted, cracked across the grain.)

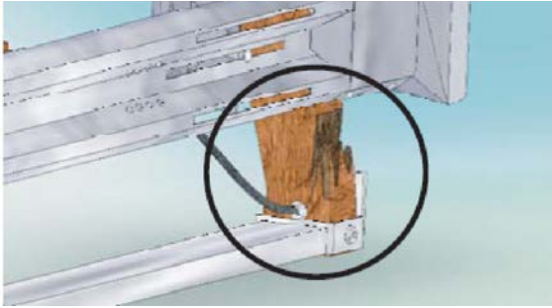

FT-MISS-CBL

Missing Anchor Cable

Missing anchor cable (usually found on a proprietary Slotted Rail Terminal with horizontal slots shown).

Anchor cable also needed on a Breakaway Cable Terminal (BCT).

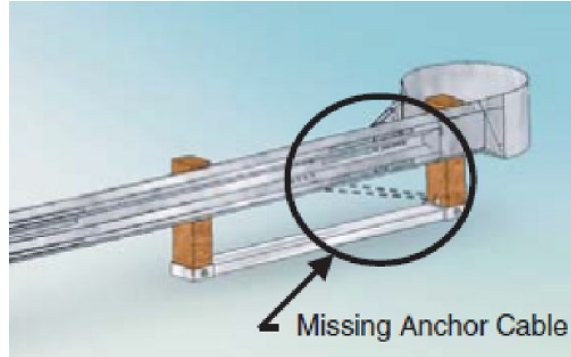

FT-TERM-OFFST

End Terminal offset too far

See G-20

2' offset maximum (almost 3' shown) For a 50' terminal.



Use $\leq 25:1$ offset rate

FT-BCT

BCT Terminals

See Regional End Terminal Replacement Guide for replacement of Breakaway Cable Terminals (BCT's), MASH requirements.

BCT's are not acceptable on 45 MPH or greater roadways or NHS (National Highway System) Routes

BCT's have no extruding head, no horizontal guardrail and no ground strut slotted



FT-MFR-INSTR

Steel Yielding

Posts on wrong side of sleeve tube

Needs to be on upstream side per manufacturer.

Follow and submit Manufacturer's Checklist for each terminal replacement.

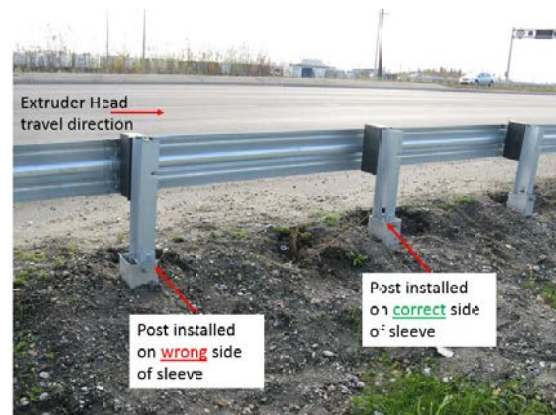

FT-NO-BRGPL

Missing

Missing bearing plate behind square washer cable bolt on end post. (See illustration page 26)

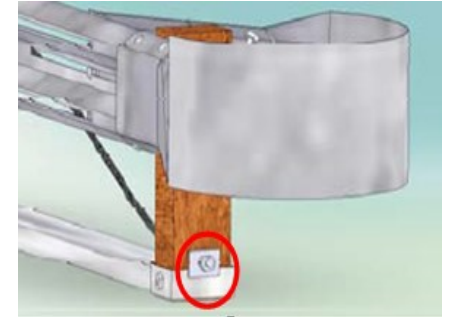

FT-MFR-INSTR

Incorrect Terminal Installation

Post or guardrail slots facing wrong way to give way on impact. Long bolts where short bolt required.

Review manufacturer's installation instructions for alignment and their checklist.



FT-LAG

Lag Screws

Missing or failed lag screws in wood post, extruding terminals Non-galvanized bolting of terminal leads to rusting, poor fit. Improper use of nails. Use manufacturer required connections.

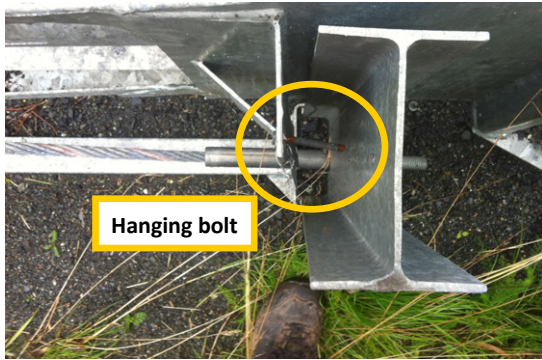

Hanging bolt

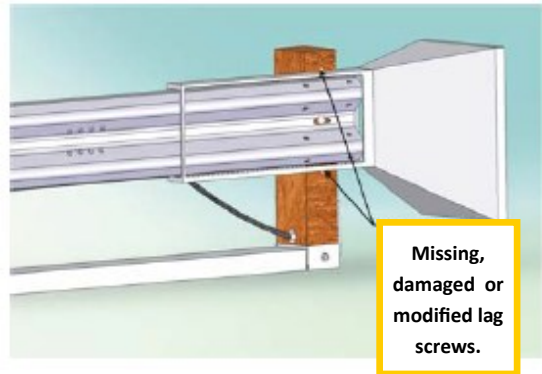

Missing, damaged or modified lag screws.

GRADE D RAIL: Damaged - Medium repair schedule

D-POST-SEP

Posts separated from rail

- 2 or more posts with block out attached with a post/rail separation less than 3".
- 1 or more posts with a post/rail separation which exceeds 3".

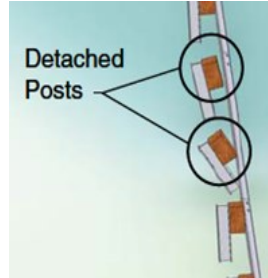

- If the block out is not firmly attached to the post, use the missing blockout guidelines.
- Damage should also be evaluated against post/rail deflection guidelines.

D-MIS-BLKT

Missing blockouts

- Any blockouts missing. (This leaves a gap to the post)
- Cracked across the grain.
- Cracked from top or bottom of blockout through post bolt hole, rotted.

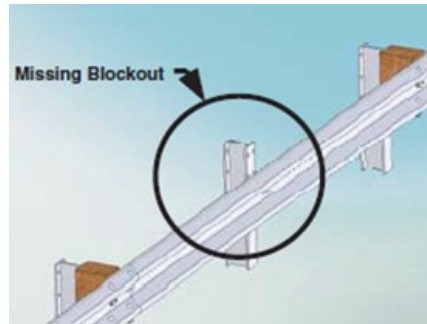

D-TWST-BLKT

Twisted blockouts

Note: Repairs of twisted blockout are relatively quick and inexpensive

(Missing galvanized 8d toe-nails may be the cause of rotation in the case of wood posts and wood blockouts)

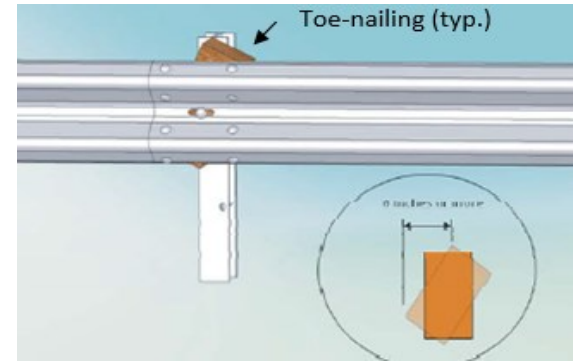

D-DEFL

Post and Rail Deflection $\leq 9"$

6-9". lateral deflection anywhere over a 25' length of guardrail or between any two adjacent posts

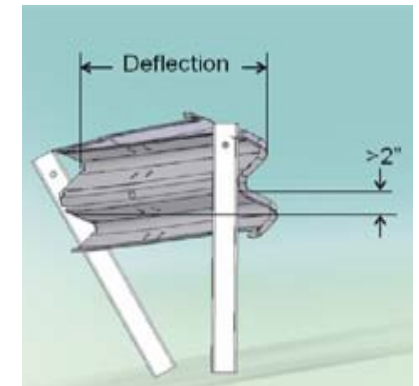

DT-FLARE

Parallel Terminal Widening

Improper flare pad or approach cross slope (proper flare shown).



See Std Plan G-20

DT-ANCHR-SPLIC

W31 End Anchor Splice incorrect

Splice needs to be mid span after second post

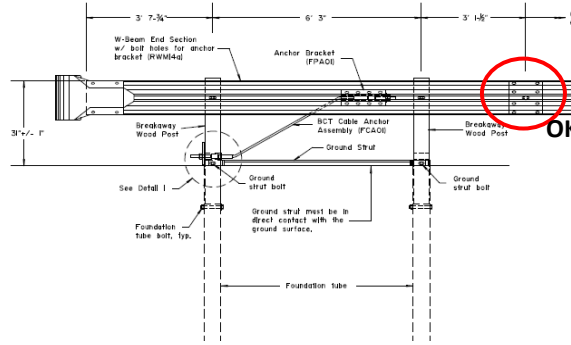

DT-BRDGEGAP

Poor bridge connection

3'9" maximum between last bridge guardrail post and thrie beam transition post.



DT-CBL-SLK

Anchor Cable

More than 1" of movement when pushed down by hand

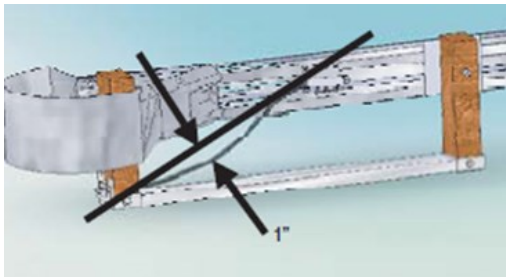

DT-BRG-PLT

Bearing Plate

Loose or misaligned

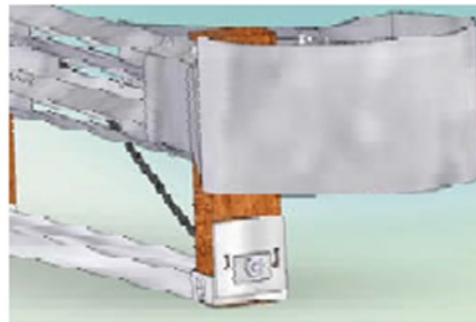

(Correct Bearing Plate)

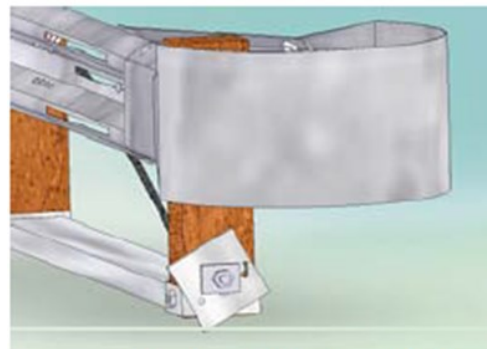

(Misaligned Bearing Plate)

GRADE ABC

ACCEPTABLE

LONG-SPAN GUARDRAIL

DT-CBL-ANCHR

Cable Anchor Bracket

Loose or not firmly seated in guardrail

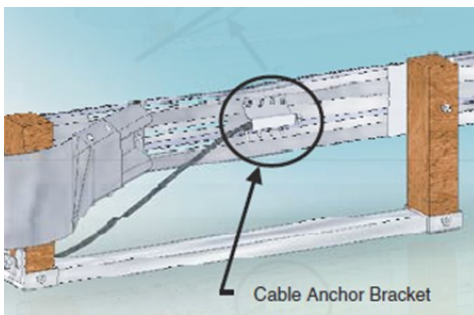

Cable Anchor Bracket

(MASH)

(New 2019 +)

See Std Plan G-29

25' max span skipping ≤ 3 posts, with W31 mid span splices

No nested guardrail

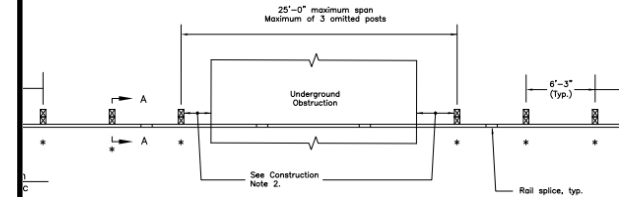

6 Wood CRT posts with holes

1 wood blockout per CRT post



(350) (2018 and prior)

Was Std Plan G-28
25' max span
≤ 3 posts for 27
3/4" w-beam,
with splice on
posts
Nested guardrail
2 wood blockouts
per CRT Post

Optional

Long-Span Concrete barrier
See design engineer for appropriate use.

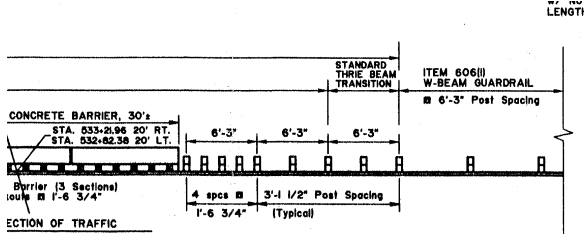

STANDARD THREE BEAM TRANSITION
ITEM 606(II) W-BEAM GUARDRAIL
6'-3" Post Spacing

CONCRETE BARRIER, 30'±
STA. 033+21.06 20' RT.
STA. 032+82.38 20' LT.

Barrier (5 Sections)
width 1'-6 3/4"

SECTION OF TRAFFIC

4 spcs 3'-1 1/2" Post Spacing
1'-6 3/4" (Typical)

BASIC END TERMINAL IDENTIFICATION GUIDE

MASH-16 TERMINALS

MSKT (MASH-16)



Road Systems Inc.

SOFT - STOP (MASH-16)



Trinity

MAX- TENSION (MASH-16)



Barrier Systems Inc.

NCHRP-350 Terminals

SKT (350)

Slotted Rail

Extruding head
Cable anchor
Ground strut –
BETWEEN posts 1 and 2
Object marker panel flush
with extruding head
"2 square" front of head
Square handle backside



Barriers Systems Inc.

3/4" bolt at hinged post #2 on downstream side of the post

5/8" bolt at hinged post #1 on upstream side of the post



Ground Strut



X-TENSION (350)



Barriers Systems Inc.

ET-PLUS

(350)

Extruding head
 Cable anchor
 Ground strut BEHIND posts 1 and 2.
 Object marker panel taller than extruding head.
 "1 square" front of head
 Triangular handle backside



Angle Strut



Flange

Trinity

SRT-350

(Slotted Guardrail Terminal) (350)

Cable Anchor
 Slotted guardrail
 Ground Strut
 Looks like BCT
 But with slots,
 ground strut



Trinity

Older Terminals

(Was Std Plan G-14)

BCT

(Breakaway cable terminal)

Cable anchor
 No ground strut
 No object marker panel



Non Proprietary

Not for V > 40 mph or main highways

X-LITE

(350)

Sliding panels
 Slider assembly post 3
 Cable anchor posts 2-3
 Ground strut rods – 2 sided
 Painted shear bolts to blackouts
 No steel soil sleeve tubes



2 rods

Barriers Systems Inc.

WY-BET

(350)

(Box beam)



Trinity

CRT (existing) Was Std Plan G-25

Features:
 Cable anchor
 No strut
 Round pipe can on end post
 Wood breakaway posts in radius.
 22" TYP HT



Non Proprietary

See G-26 for new Short Radius Terminal version (31" ± 1")

CRASH CUSHIONS

Low Maintenance, "Self restoring"
 Complete Manufacturer's installation checklist.
 Check with Traffic and Safety before installing.

TAU II - R (350)



Barriers Systems Inc.

REACT (350)



Energy Absorption

TANGENT LENGTH OF NEED

$$LON = \frac{L_H - L_2}{\frac{L_H}{L_R}}$$

Source: DOT&PF Highway Preconstruction Manual Fig 1.130-4

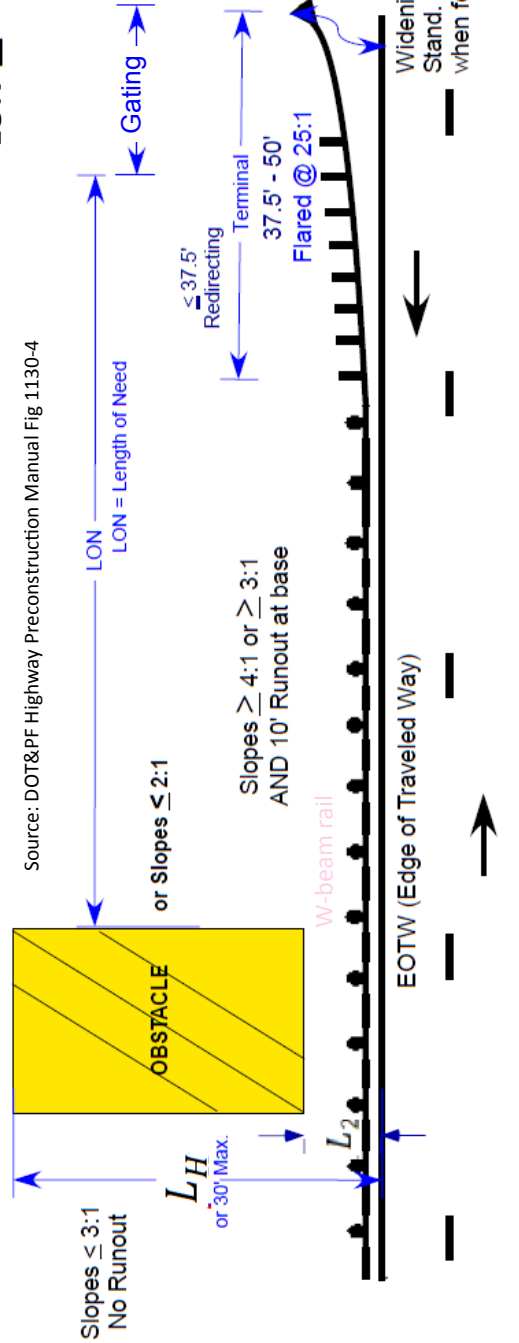

FLARE + PARABOLIC LENGTH OF NEED

$$LON = \frac{(L_H - L_2) + \frac{b}{a} L_1 - \frac{a(P)}{\sqrt{a^2 + b^2}}}{\frac{L_H}{L_R} + \frac{b}{a}}$$

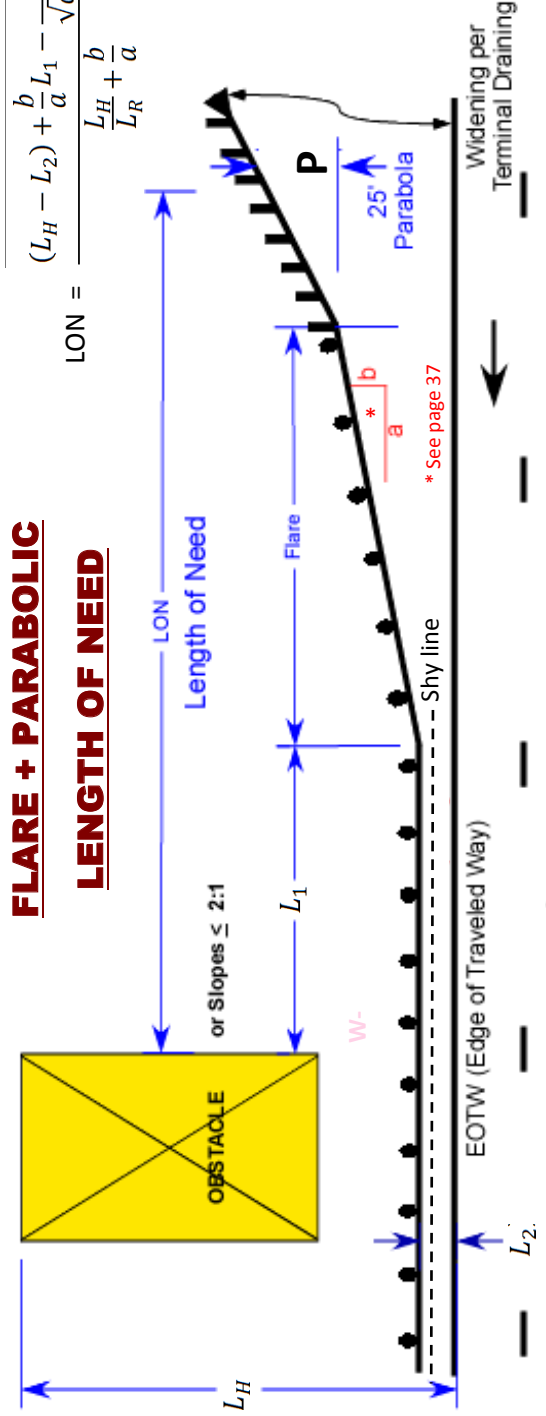

Table 1130-9

Recommended Shy Line Offsets

Design Speed (mph)	Recommended Shy Line Offsets (feet)
80	12.1
75	10.5
70	10.0
60	8.0
55	7.2
50	6.5
45	5.5
40	5.0
30	3.5

Table 1130-10

Flare Rates for Barrier Design (b/a)

Design Speed (mph)	Flare Rate for Barrier Inside the Shy Line (b/a)	Flare Rate for Barrier Beyond the Shy Line (b/a)	
		1:20*	1:15**
70	1:30	1:20*	1:15**
60	1:26	1:18*	1:14**
55	1:24	1:16*	1:12**
50	1:21	1:14*	1:11**
45	1:18	1:12*	1:10**
40	1:16	1:10*	1:8**
30	1:13	1:8*	1:7**

- * Suggested maximum flare rate for rigid barrier systems.
- ** Suggested Maximum flare rate for semi-rigid systems.

Table 1130-11

Recommended Runout Length for Barrier Advancement Length Determination

Design Speed (mph)	Traffic Volume (ADT)			
	Over 10,000	5,000 to 10,000	1,000 to 4,999	Under 1,000
70	360	330	290	250
65	330	290	250	225
60	300	250	210	200
55	265	220	185	175
50	230	190	160	150
45	195	160	135	125
40	160	130	110	100
35	135	110	95	85
30	110	90	80	70

Tables excerpted from:
(DOT&PF Highway Preconstruction Manual)
as of 3-22-19

Manufacturers

Trinity Industries
<http://www.trinityhighway.com/>
<http://www.energyabsorption.com/>

BSI
<http://www.barriersystemsinc.com/>

RSI
<http://www.roadsystems.com/>

Suppliers

UIS
<https://www.uisutah.com/>
Phone: 800-424-9825

Coral Sales
<http://www.coralsales.com/>
Phone: 503-655-6351

Installers

Acme Fence
<http://acmefence.net/>
Phone: 907-522-1155

McKinley Fence
<http://www.mckinleyfence.com/>
Phone: 907-563-3731

Northwest Barrier
<https://www.nwbarriers.com/>
Phone: 907-376-7498

Abbreviations

MASH: Manual for Assessing Safety Hardware

NCHRP: National Cooperative Highway Research Program

HPM: Highway Preconstruction Manual

CRT: Controlled Released Terminal

Notes

This guide is based on NCHRP 656, Std Plans, and DOT&PF experience.

This guide is for use by DOT&PF Design, Construction, and/or Maintenance in planning or prioritizing repair and replacement of existing guardrail through field observation/inspection.

Observe safe procedures when inspecting near traffic. Wear high visibility garments and use a vehicle with beacons when needed. Avoid blocking of traffic lanes for inspection. Use pullouts, driveways, and shoulders when possible during notetaking. Consider drive through video recording.

For question or comments contact the Regional Traffic & Safety Engineer.